



NGP-4055/6055/7055/9055-HY Direct Hydraulic Drive Piston Pump Operation Manual Addendum



Please refer to the 12-M-43 NGP parts and instruction manual for more details about pump service, storage, and common parts. Refer to the 12-M-56 Hyd Drive Kit manual to get system setting information.

WARNING: USE OF THIS PRODUCT FOR ANY PURPOSES OTHER THAN ITS ORIGINAL INTENT, ABUSE OF THE PRODUCT, AND/OR MODIFICATION TO THE ORIGINAL PRODUCT IS STRICTLY PROHIBITED BY CDS-JOHN BLUE COMPANY. CDS-JOHN BLUE COMPANY RESERVES THE RIGHT TO DENY WARRANTY OR LIABILITY CLAIMS IN ANY/ALL SITUATIONS INVOLVING MISUSE, ABUSE OR MODIFICATION.

THE ORIGINAL INTENT OF THIS PRODUCT DOES NOT INCLUDE USE WHERE THE MAXIMUM ALLOWED PRESSURE OR TEMPERATURE IS EXCEEDED, AND IT DOES NOT INCLUDE APPLICATIONS UTILIZING FLUIDS THAT ARE NOT COMPATIBLE WITH THE PRODUCT'S COMPONENT MATERIALS. DO NOT USE THIS PRODUCT WITH FLAMMABLE OR COMBUSTIBLE FLUIDS SUCH AS GASOLINE, KEROSENE, DIESEL, ETC.... DO NOT USE IN EXPLOSIVE ATMOSPHERES, AND DO NOT USE WITH ANHYDROUS AMMONIA (NH3). FAILURE TO FOLLOW THIS NOTICE MAY RESULT IN SERIOUS INJURY AND/OR PROPERTY DAMAGE AND WILL VOID THE PRODUCT WARRANTY. IF IN DOUBT ABOUT YOUR APPLICATION, CONTACT YOUR STOCKING DEALER OR THE CDS-JOHN BLUE TECHNICAL STAFF AT 1-800-253-2583.

WARNING: This product can expose you to certain chemicals, which are known to the State of California to cause cancer or birth defects or other reproductive harm. For more information go to: www.P65Warnings.ca.gov.

Pump Specifications:

Operating Pressure: MAX 120 PSI Hyd. Motor Interface: SAE A 2-bolt flange, 1" keyed shaft
 Operating Speed: MAX 550 RPM Crankcase Lubrication: SAE 90 Gear Oil

Pump Series:	NGP-4055	NGP-6055	NGP-7055	NGP-9055	
Output Volume	10.2	21.0	34.2	68.4	Max Gal/Min
Output Disp.	0.019	0.039	0.062	0.124	Gal/Rev
Crankcase Oil Cap.	0.5	0.5	1.5	5.4	Pints
Inlet/Outlet Ports	1"	1-1/2"	1-1/2"	1-1/2"	Female Pipe Thread
Optional Flanges	200	220	220	220	Flange Size

Installation and Operation:

1. As per the 12-M-43 NGP pump manual, the pump should be mounted in a horizontal position with the supplied bolts, and the vented crankcase plug should be installed in the top crankcase hole before use.

2. An SAE "A" 2-bolt hydraulic motor can be installed after greasing the shaft and aligning the keyway with the shaft. Do not remove the studs from the crankcase because oil will leak out if you do. The stud threads may be re-sealed if required with a silicone sealant or gasket compound – be sure to let the compound set up before submersing it in oil.

Note: if the motor does not slide onto the shaft easily until it is fully seated, do not force it into the pump. Remove the motor and look for burrs.

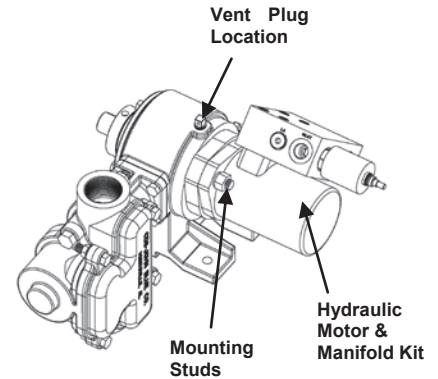

3. CDS-John Blue has a hydraulic motor / pwm manifold kit available for the direct drive pumps, part number **116205-91**. This kit includes the: motor, pwm manifold, hydraulic elbows for inlet and outlet, hardware, and setup instructions. The hydraulic motor in the kit requires .021 gallons per revolution, so to achieve 550 rpm approximately 11.5 gpm will be required. Note that the pump max speed is 550 rpm, and the rotation does not matter.

4. The instruction manual (#12-M-54) supplied with the above motor/manifold kit has detailed information about the hydraulic requirements for the motor, and on how to set up the pwm valve for various control systems. The manual is available at: www.cds-johnblue.com

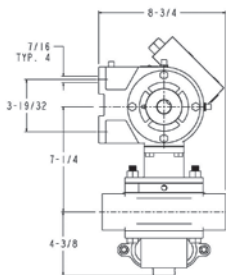

NGP-6055-HY

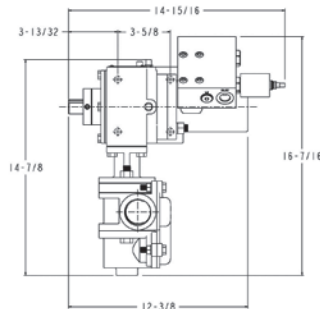

NGP-7055-HY

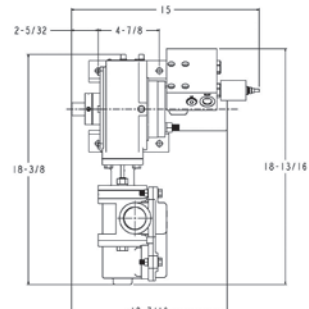
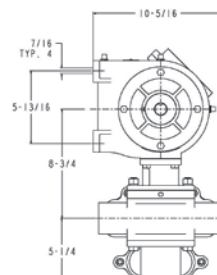

Parts Specific to Direct Hydraulic Drive Models:

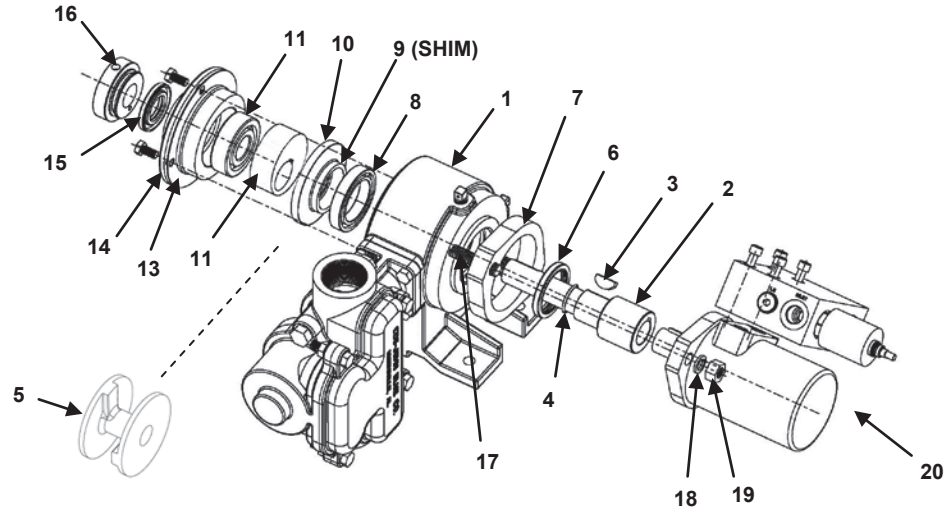

ITEM	PART DESCRIPTION	NGP-40/6055-HY PART #	NGP-7055-HY PART #	NGP-9055-HY PART #
1	CRANKCASE	116194-01	116201-01	116274-01
2	MAIN SHAFT	116195-01	116195-01	116276-01
3	WOODRUFF KEY	108093-01	108093-01	108093-01
4	SHAFT SPACER (7055 ONLY)	N/A	116204-01	N/A
5	SPACER SLEEVE (9055 ONLY)	N/A	N/A	116275-01
6	DRIVE SIDE SEAL	116199-01	116199-01	116199-01
7	MOTOR SPACER	116200-01	116200-01	116200-01
8	DRIVE SIDE BEARING	116198-01	116198-01	116198-01
9	DRIVE SIDE SHIM (7055/9055 ONLY)	N/A	116343-01	116343-01
10	BEARING SPACER	116197-01	116203-01	116203-01
11	ECCENTRIC	116196-01	116202-01	116202-01
12	OUTBOARD BEARING	L-3019	L-3019	L-3019
13	COVER PLATE GASKET	L-1006	L-3002	L-3002
14	COVER PLATE	115723-01	115623-01	115623-01
15	OUTBOARD SEAL	115621-01	115621-01	115621-01
16	SHAFT COLLAR ASSEM	115624-91	115624-91	115624-91
17	STUD - 1/2"-13 X 3" LG	90716	90716	90716
18	1/2" LW, PLATED	93004	93004	93004
19	1/2"-13 NUT, PLATED	92029	92029	92029
20	OPTIONAL HYDRAULIC MOTOR & MANIFOLD ASSEMBLY	116205-91	116205-91	116205-91



CDS-John Blue Company

Division of Advanced Systems Technology

165 Electronics Blvd., Huntsville AL 35806

Telephone: (256) 721-9090 • Fax (256)-721-9091 • Toll Free 1-800-253-2583

www.cds-johnblue.com

YOUR LOCAL DEALER

